

SYSTEM MODEL		GLS-400-LH	CSS-400-LH
	Design Flow Rate, GPM	340@30 TDH	340@40 TDH
Item 1	Separator Model	CS-4T-FLG Carbon Steel, Powder Coated	
Item 2	Frame Construction	Carbon Steel, Powder Coated	
Item 3	Pipe Assembly	Carbon Steel, Rust Inhibitor Primer with Enamel finish	
MOTOR 460 VAC TEFC			
Item 4	Horsepower	5 hp	5 hp
	Approximate Amps @ 460V	7.6 amps	7.6 amps
	RPM	3500	
PUMP			
Item 5	Pump Casing	Cast Iron	
	Pump Impeller	Bronze	
	Std. Mechanical Seal	VITON Elastomer, Silicon Carbide Seat, Carbon Rotary	
BASKET STRAINER (Optional)			
Item 6	Body Construction	Cast Iron	
	Internal Screen	1/4" Perforated 304 Stainless Steel	
	Connection Type	Class 150 Flange	
CONTROL PANEL (UL listed and labeled, manufactured to UL-508A Std.)			
Item 7	Enclosure	NEMA 4 Powder Coated, Watertight, UL listed and CSA approved	
	Electrical Components	Starter with Thermal Overload, HOA, 460/120 Transformer with Circuit Breakers, Pump "RUN" Light, Lockable Door Disconnect, Magnetic Contactor, Purge Timer, Manufactured with all UL listed & CSA approved electrical components.	
PURGE VALVE (Requires Power to Open and Power to Close. Must Close Manually if Open During a Power Outage)			
Item 8	Actuator, Motorized	120 VAC 60Hz	
	Connection Type	1-1/2" Female NPT, Ball Valve	
SPECIFICATIONS			
	Dim "A"	55-1/2"	
	Dim "B"	41-1/2"	
	Dim "C"	36"	
	Max. Inlet P.S.I.	100	
	Max. Operating P.S.I.	150	
	Max. Operating Temp.	100°F	
	Inlet with or without Strainer (Class 150 Flange)	4"	
	Outlet (Class 150 Flange)	4"	
	Shipping Weight	800 Lbs	

Note: Dimensions are approximate and are for reference only. Dimensions subject to change without notice. Weights are approximate.

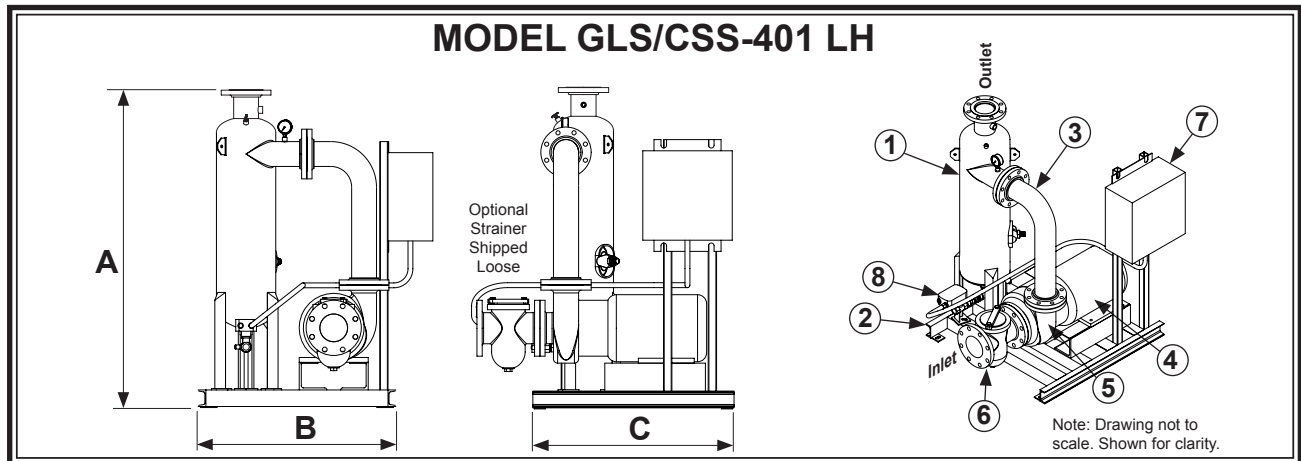

SYSTEM MODEL		GLS-401-LH	CSS-401-LH
	Design Flow Rate, GPM	420@30 TDH	420@40 TDH
Item 1	Separator Model	CS-4T-FLG Carbon Steel, Powder Coated	
Item 2	Frame Construction	Carbon Steel, Powder Coated	
Item 3	Pipe Assembly	Carbon Steel, Rust Inhibitor Primer with Enamel finish	
MOTOR 460 VAC TEFC			
Item 4	Horsepower	7.5 hp	
	Approximate Amps @ 460V	11 amps	
	RPM	3500	
PUMP			
Item 5	Pump Casing	Cast Iron	
	Pump Impeller	Bronze	
	Std. Mechanical Seal	VITON Elastomer, Silicon Carbide Seat, Carbon Rotary	
BASKET STRAINER (Optional)			
Item 6	Body Construction	Cast Iron	
	Internal Screen	1/4" Perforated 304 Stainless Steel	
	Connection Type	Class 150 Flange	
CONTROL PANEL (UL listed and labeled, manufactured to UL-508A Std.)			
Item 7	Enclosure	NEMA 4 Powder Coated, Watertight, UL listed and CSA approved	
	Electrical Components	Starter with Thermal Overload, HOA, 460/120 Transformer with Circuit Breakers, Pump "RUN" Light, Lockable Door Disconnect, Magnetic Contactor, Purge Timer, Manufactured with all UL listed & CSA approved electrical components.	
PURGE VALVE (Requires Power to Open and Power to Close. Must Close Manually if Open During a Power Outage)			
Item 8	Actuator, Motorized	120 VAC 60Hz	
	Connection Type	1-1/2" Female NPT, Ball Valve	
SPECIFICATIONS			
	Dim "A"	55-1/2"	
	Dim "B"	41-1/2"	
	Dim "C"	36"	
	Max. Inlet P.S.I.	100	
	Max. Operating P.S.I.	150	
	Max. Operating Temp.	100°F	
	Inlet with or without Strainer (Class 150 Flange)	4"	
	Outlet (Class 150 Flange)	4"	
	Shipping Weight	800 Lbs	

Note: Dimensions are approximate and are for reference only. Dimensions subject to change without notice. Weights are approximate.