

SYSTEM MODEL		GLR-800-HH	CSR-800-HH
	Design Flow Rate, GPM	1400@40 TDH	1400@80 TDH
Item 1	Separator Model	CS-8T-FLG Carbon Steel, Powder Coated	
Item 2	Frame Construction	Carbon Steel, Powder Coated	
Item 3	Pipe Assembly	Carbon Steel, Rust Inhibitor Primer with Enamel Finish	
<b>MOTOR 460 VAC TEFC</b>			
Item 4	Horsepower	20 hp	40 hp
	Approximate Amps @ 460V	27 amps	52 amps
	RPM	1750	
<b>PUMP</b>			
Item 5	Pump Casing	Cast Iron	
	Pump Impeller	Bronze	
	Std. Mechanical Seal	VITON Elastomer, Silicon Carbide Seat, Carbon Rotary	
<b>BASKET STRAINER (Optional)</b>			
Item 6	Body Construction	Cast Iron	
	Internal Screen	1/4" Perforated 304 Stainless Steel	
	Connection Type	Class 150 Flange	
<b>CONTROL PANEL (UL listed and labeled, manufactured to UL-508A Std.)</b>			
Item 7	Enclosure	NEMA 4 Powder Coated, Watertight, UL listed and CSA approved	
	Electrical Components	Starter with Thermal Overload, HOA, 460/120 Transformer with Circuit Breakers, Pump "RUN" Light, Lockable Door Disconnect, Magnetic Contactor, Manufactured with all UL listed & CSA approved electrical components.	
	Service Light (Optional)	25 Watt, Amber, 120 VAC	
<b>RECOVERY TANK</b>			
Item 8	Body Construction	304 Stainless Steel	
	Internal Screen	304 Stainless Steel	
	Filter Bag	25 Micron Polypropylene	
	Differential Press. Switch	Dial Indicator with N.O. Dry Contact	
<b>SPECIFICATIONS</b>			
	Dim "A"	79-1/2"	
	Dim "B"	54-15/16"	
	Dim "C"	37"	
	Max. Inlet P.S.I.	100	
	Max. Operating P.S.I.	150	
	Max. Operating Temp.	120°F	
	Inlet (Class 150 Flange)	8"	
	Outlet (Class 150 Flange)	8"	
	Shipping Weight	2800 Lbs	

Note: Dimensions are approximate and are for reference only. Dimensions subject to change without notice. Weights are approximate.

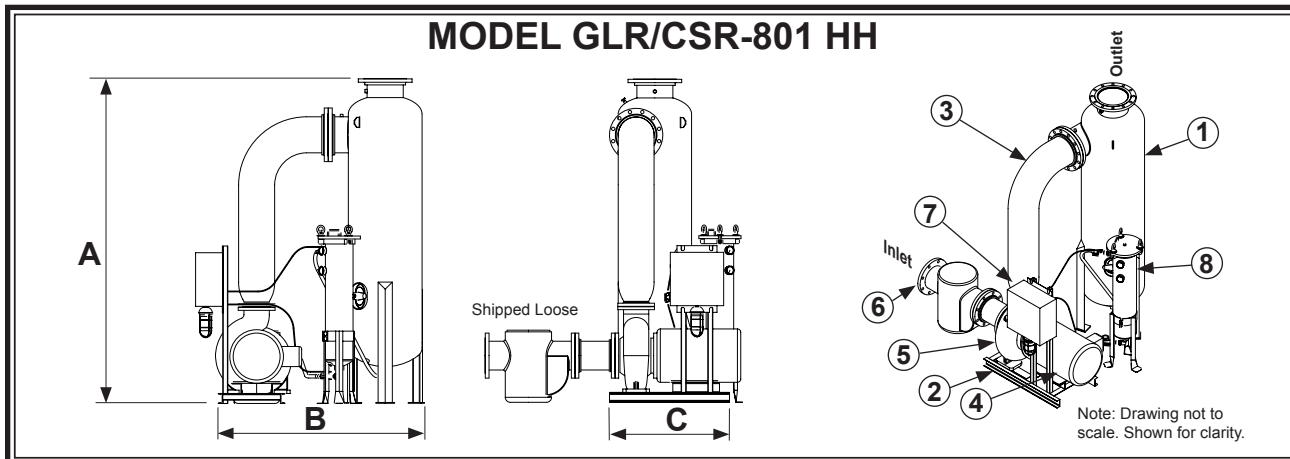

**SECTION 2**

SYSTEM MODEL		CSR-800-HH	CSR-801-HH
	Design Flow Rate, GPM	1700@40 TDH	1700@80 TDH
Item 1	Separator Model	CS-8T-FLG Carbon Steel, Powder Coated	
Item 2	Frame Construction	Carbon Steel, Powder Coated	
Item 3	Pipe Assembly	Carbon Steel, Rust Inhibitor Primer with Enamel Finish	
<b>MOTOR 460 VAC TEFC</b>			
Item 4	Horsepower	25 hp	50 hp
	Approximate Amps @ 460V	34 amps	65 amps
	RPM	1750	
<b>PUMP</b>			
Item 5	Pump Casing	Cast Iron	
	Pump Impeller	Bronze	
	Std. Mechanical Seal	VITON Elastomer, Silicon Carbide Seat, Carbon Rotary	
<b>BASKET STRAINER (Optional)</b>			
Item 6	Body Construction	Cast Iron	
	Internal Screen	1/4" Perforated 304 Stainless Steel	
	Connection Type	Class 150 Flange	
<b>CONTROL PANEL (UL listed and labeled, manufactured to UL-508A Std.)</b>			
Item 7	Enclosure	NEMA 4 Powder Coated, Watertight, UL listed and CSA approved	
	Electrical Components	Starter with Thermal Overload, HOA, 460/120 Transformer with Circuit Breakers, Pump "RUN" Light, Lockable Door Disconnect, Magnetic Contactor, Manufactured with all UL listed & CSA approved electrical components.	
	Service Light (Optional)	25 Watt, Amber, 120 VAC	
<b>RECOVERY TANK</b>			
Item 8	Body Construction	304 Stainless Steel	
	Internal Screen	304 Stainless Steel	
	Filter Bag	25 Micron Polypropylene	
	Differential Press. Switch	Dial Indicator with N.O. Dry Contact	
<b>SPECIFICATIONS</b>			
	Dim "A"	79-1/2"	
	Dim "B"	54-15/16"	
	Dim "C"	37"	
	Max. Inlet P.S.I.	100	
	Max. Operating P.S.I.	150	
	Max. Operating Temp.	120°F	
	Inlet (Class 150 Flange)	8"	
	Outlet (Class 150 Flange)	8"	
	Shipping Weight	2800 Lbs	

Note: Dimensions are approximate and are for reference only. Dimensions subject to change without notice. Weights are approximate.

**Section 2, Page 13**

REV. 07/10