

MODEL 3T-20T FLG

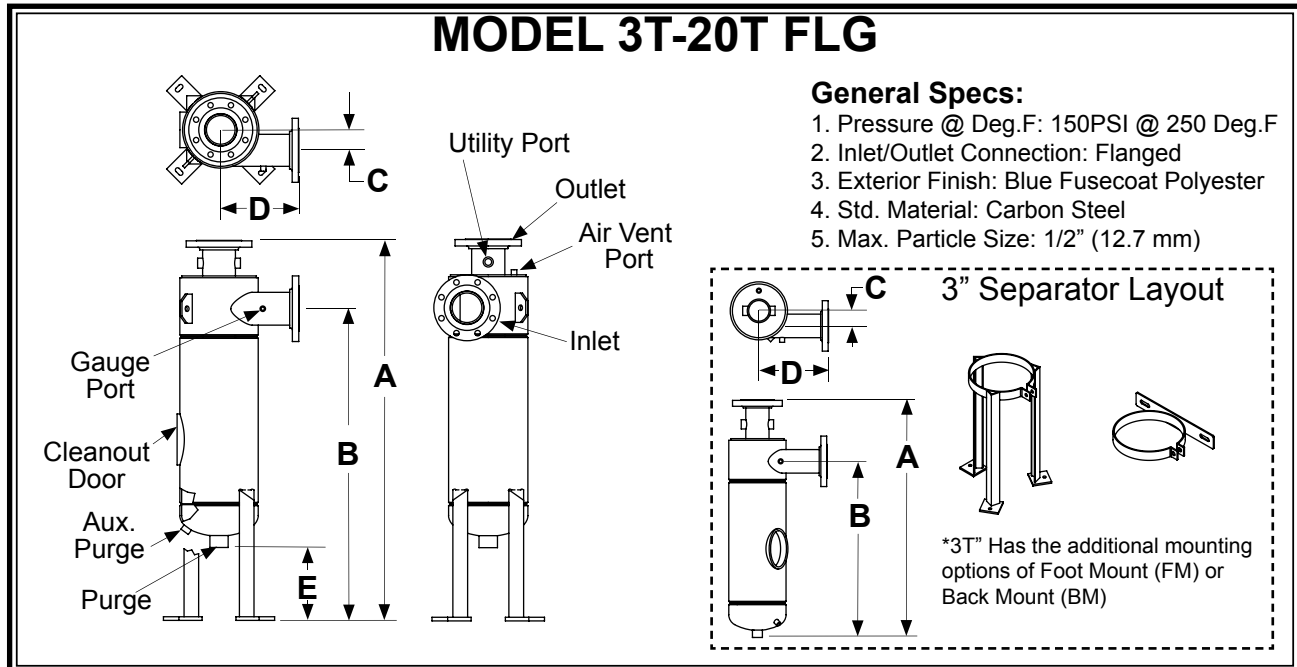

SIZE	FLOW RANGE GPM (m ³ /hr)	INLET/ OUTLET	DIMENSIONS Inches/(mm)					PURGE	AUX. PURGE	CLEANOUT DOOR Inches (mm)	UTILITY PORT	GAUGE PORT	AIR VENT PORT
			A	B	C	D	E						
3T	115-280 (26-63)	3" CLASS 150	35-3/8 (899)	26-1/4 (667)	2-1/4 (57)	10-1/2 (267)	N/A	1" FNPT		3x4 (76x102)			
4T	190-450 (43-102)	4" CLASS 150	52-1/8 (1324)	42-3/4 (1086)	2-7/8 (73)	11 (279)	10 (254)	1-1/2" FNPT	3/4" FNPT	4x6 (102x152)	3/4" FNPT	1/4" FNPT	
5T	310-710 (70-161)	5" CLASS 150	59-1/2 (1511)	49 (1245)	3-5/16 (84)	12 (305)							
6T	440-1200 (100-272)	6" CLASS 150	65-1/2 (1664)	54-3/4 (1391)	3-7/16 (87)	13 (330)		2" FNPT	1" FNPT				6x8 (152x203)
8T	790-1800 (179-408)	8" CLASS 150	79-1/2 (2019)	67-1/8 (1705)	4-7/16 (113)	15 (381)							
10T	1250-2800 (284-636)	10" CLASS 150	93-1/2 (2375)	80-1/8 (2035)	5-3/8 (137)	17 (432)							
12T	1750-3900 (397-885)	12" CLASS 150	109-3/8 (2778)	94-5/8 (2403)	6-3/8 (162)	18 (457)	12 (305)						
14T	2400-5000 (545-1135)	14" CLASS 150	CONSULT FACTORY										
16T	3300-6800 (749-1544)	16" CLASS 150											
18T	4000-8200 (908-1861)	18" CLASS 150											
20T	6100-12000 (1385-2724)	20" CLASS 150											

SHIPPING WEIGHT

	3T	4T	5T	6T
Lbs.	122	280	300	375
Kg.	55	127	136	170
	8T	10T	12T	14T
Lbs.	560	850	1200	1385
Kg.	254	386	544	628
	16T	18T	20T	
Lbs.	1720	2350	3100	
Kg.	780	1066	1406	

OPTIONS: (See Reverse Side for Model Configuration Matrix)

- Stainless Steel
 - Non-Std. Press. Requirements
 - Low Profile
- (Consult Factory)

MODEL 3T-20T FLG

SECTION 1

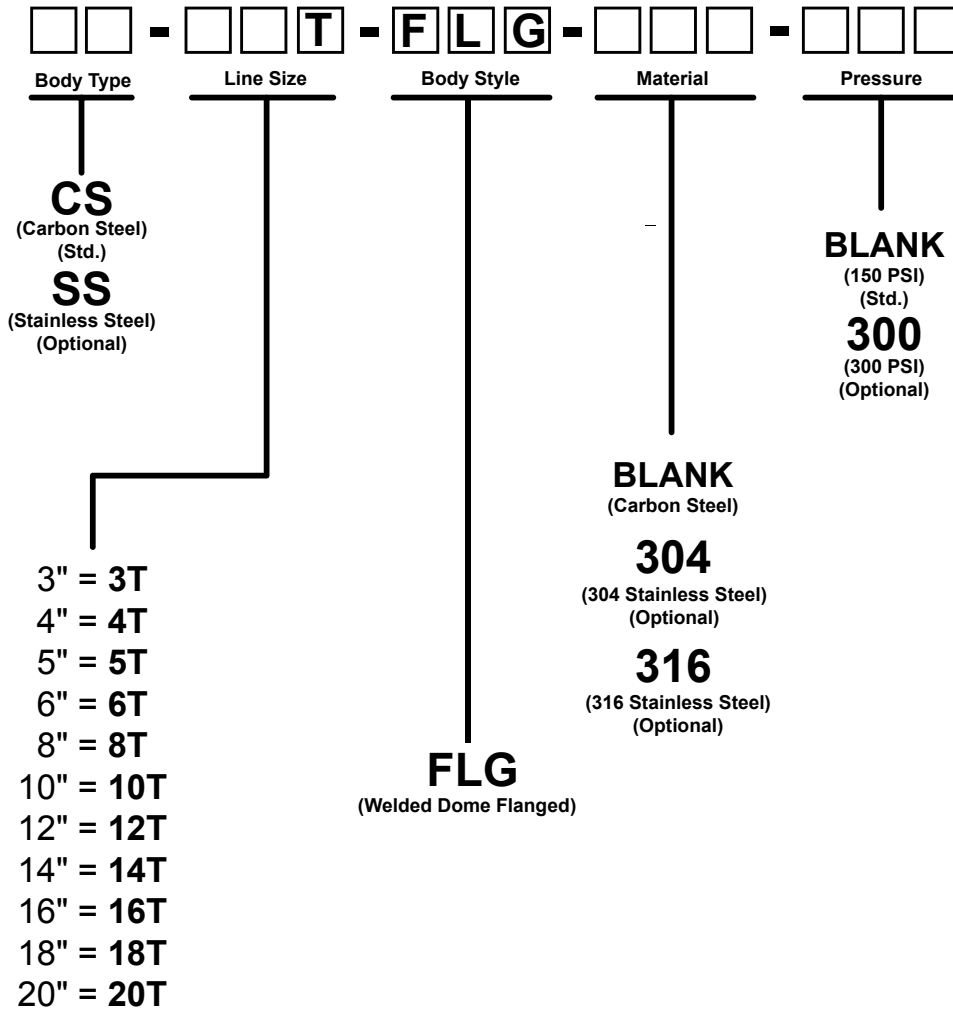

To determine pressure loss requirements - enter the chart below left at the "flow rate" desired, move vertically to the separator "size line", move to the left to the "pressure loss" line. To determine efficiencies - enter the chart below left at the "flow rate" desired, move vertically to the separator "size line", move horizontally to the chart below right and intersect the Specific Gravity/efficiency line.

